



TF

Welding Neck Flange Slip On Flange Blind Flange



CLASS 150 - 300# ANSI

150 lb/sq. in. Slip-on Flanges

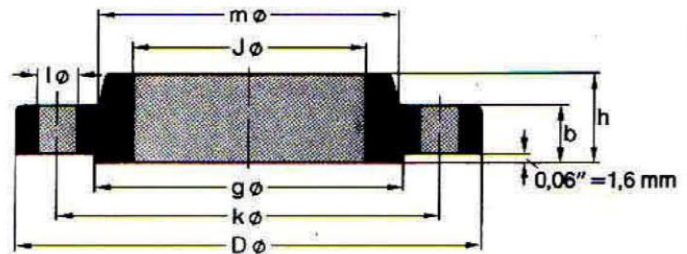

ANSI B 16.5

Pipe		Flange				Hub	Raised Face	Drilling Template			Approx. Weight
Nom. Size	O D in. mm	D in. mm	J in. mm	b in. mm	h in. mm	m in. mm	g in. mm	Number	l in. mm	k in. mm	≈ Pounds Kilo
1/2"	0,84 21,3	3,50 88,9	0,88 22,4	0,44 11,2	0,62 15,7	1,19 30,2	1,38 35,1	4	0,62 15,7	2,38 60,5	0,9 0,39
3/4"	1,05 26,7	3,88 98,6	1,09 27,7	0,50 12,7	0,62 15,7	1,50 38,1	1,69 42,9	4	0,62 15,7	2,75 69,9	1,2 0,56
1"	1,315 33,4	4,25 108,0	1,36 34,5	0,56 14,2	0,69 17,5	1,94 49,3	2,00 50,8	4	0,62 15,7	3,12 79,2	1,7 0,78
1 1/4"	1,66 42,2	4,62 117,3	1,70 43,2	0,62 15,7	0,81 20,6	2,31 58,7	2,50 63,5	4	0,62 15,7	3,50 88,9	2,3 1,03
1 1/2"	1,90 48,3	5,00 127,0	1,95 49,5	0,69 17,5	0,88 22,4	2,56 65,0	2,88 73,2	4	0,62 15,7	3,88 98,6	2,9 1,32
2"	2,375 60,3	6,00 152,4	2,44 62,0	0,75 19,1	1,00 25,4	3,06 77,7	3,62 91,9	4	0,75 19,1	4,75 120,7	4,5 2,06
2 1/2"	2,875 73,0	7,00 177,8	2,94 74,7	0,88 22,4	1,12 28,4	3,56 90,4	4,12 104,6	4	0,75 19,1	5,50 139,7	7,2 3,28
3"	3,50 88,9	7,50 190,5	3,57 90,7	0,94 23,9	1,19 30,2	4,25 108,0	5,00 127,0	4	0,75 19,1	6,00 152,4	8,5 3,85
3 1/2"	4,00 101,6	8,50 215,9	4,07 103,4	0,94 23,9	1,25 31,8	4,81 122,2	5,50 139,7	8	0,75 19,1	7,00 177,8	10,6 4,81
4"	4,50 114,3	9,00 228,6	4,57 116,1	0,94 23,9	1,31 33,3	5,31 134,9	6,19 157,2	8	0,75 19,1	7,50 190,5	11,7 5,30
5"	5,563 141,3	10,00 254,0	5,66 143,8	0,94 23,9	1,44 36,6	6,44 163,6	7,31 185,7	8	0,88 22,4	8,50 215,9	13,4 6,07
6"	6,625 168,3	11,00 279,4	6,72 170,7	1,00 25,4	1,56 39,6	7,56 192,0	8,50 215,9	8	0,88 22,4	9,50 241,3	16,4 7,45
8"	8,625 219,1	13,50 342,9	8,72 221,5	1,12 28,4	1,75 44,5	9,69 246,1	10,62 269,7	8	0,88 22,4	11,75 298,5	26,7 12,1
10"	10,75 273	16,00 406,4	10,88 276,4	1,19 30,2	1,94 49,3	12,00 304,8	12,75 323,9	12	1,00 25,4	14,25 362,0	36,3 16,5
12"	12,75 323,8	19,00 482,6	12,88 327,2	1,25 31,8	2,19 55,6	14,38 365,3	15,00 381,0	12	1,00 25,4	17,00 431,8	57,7 26,2
14"	14,0 355,6	21,00 533,4	14,14 359,2	1,38 35,1	2,25 57,2	15,75 400,1	16,25 412,8	12	1,12 28,4	18,75 476,3	76,2 34,6
16"	16,0 406,4	23,50 596,9	16,16 410,5	1,44 36,6	2,50 63,5	18,00 457,2	18,50 469,9	16	1,12 28,4	21,25 539,8	98,7 44,8
18"	18,0 457,2	25,00 635,0	18,18 461,8	1,56 39,6	2,69 68,3	19,88 505,0	21,00 533,4	16	1,25 31,8	22,75 577,9	108 48,9
20"	20,0 508	27,50 698,5	20,20 513,1	1,69 42,9	2,88 73,2	22,00 558,8	23,00 584,2	20	1,25 31,8	25,00 635,0	136 61,9
24"	24,0 609,6	32,00 812,8	24,25 616,0	1,88 47,8	3,25 82,6	26,12 663,4	27,25 692,2	20	1,38 35,1	29,50 749,3	191 86,9

150 lb/sq. in. Welding Neck Flanges

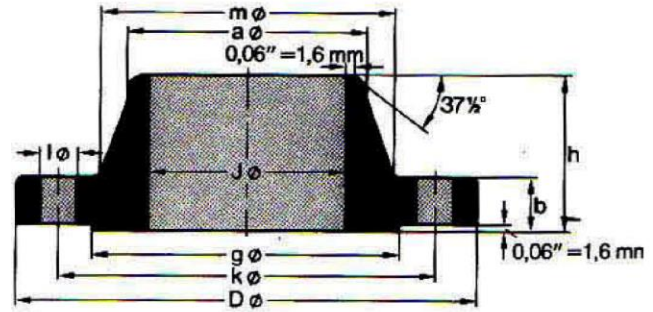

ANSI B 16.5

Pipe		Flange				Hub		Raised Face	Drilling Template			Approx. Weight
Nom. Size	O D in. mm	D in. mm	J in. mm	b in. mm	h in. mm	a in. mm	m in. mm	g in. mm	Number	l in. mm	k in. mm	≈ Pounds Kilo
1/2"	0,84 21,3	3,50 88,9	0,62 15,7	0,44 11,2	1,88 47,8	0,84 21,3	1,19 30,2	1,38 35,1	4	0,62 15,7	2,38 60,5	1,1 0,48
3/4"	1,05 26,7	3,88 98,6	0,82 20,8	0,50 12,7	2,06 52,3	1,05 26,7	1,50 38,1	1,69 42,9	4	0,62 15,7	2,75 69,9	1,6 0,71
1"	1,315 33,4	4,25 108,0	1,05 26,7	0,56 14,2	2,19 55,6	1,32 33,5	1,94 49,3	2,00 50,8	4	0,62 15,7	3,12 79,2	2,2 1,01
1 1/4"	1,66 42,2	4,62 117,3	1,38 35,1	0,62 15,7	2,25 57,2	1,66 42,2	2,31 58,7	2,50 63,5	4	0,62 15,7	3,50 88,9	2,9 1,33
1 1/2"	1,90 48,3	5,00 127,0	1,61 40,9	0,69 17,5	2,44 62,0	1,90 48,3	2,56 65,0	2,88 73,2	4	0,62 15,7	3,88 98,6	3,8 1,72
2"	2,375 60,3	6,00 152,4	2,07 52,6	0,75 19,1	2,50 63,5	2,38 60,5	3,06 77,7	3,62 91,9	4	0,75 19,1	4,75 120,7	5,7 2,58
2 1/2"	2,875 73,0	7,00 177,8	2,47 62,7	0,88 22,4	2,75 69,9	2,88 73,2	3,56 90,4	4,12 104,6	4	0,75 19,1	5,50 139,7	9,1 4,11
3"	3,50 88,9	7,50 190,5	3,07 78,0	0,94 23,9	2,75 69,6	3,50 88,9	4,25 108,0	5,00 127,0	4	0,75 19,1	6,00 152,4	10,8 4,92
3 1/2"	4,00 101,6	8,50 215,9	3,55 90,2	0,94 23,9	2,81 71,4	4,00 101,6	4,81 122,2	5,50 139,7	8	0,75 19,1	7,00 177,8	13,4 6,08
4"	4,50 114,3	9,00 228,6	4,03 102,4	0,94 23,9	3,00 76,2	4,50 114,3	5,31 134,9	6,19 157,2	8	0,75 19,1	7,50 190,5	15,1 6,84
5"	5,563 141,3	10,00 254,0	5,05 128,3	0,94 23,9	3,50 88,9	5,56 141,2	6,44 163,6	7,31 185,7	8	0,88 22,4	8,50 215,9	18,9 8,56
6"	6,625 168,3	11,00 279,4	6,07 154,2	1,00 25,4	3,50 88,9	6,63 168,4	7,56 192,0	8,50 215,9	8	0,88 22,4	9,50 241,3	23,3 10,6
8"	8,625 219,1	13,50 342,9	7,98 202,7	1,12 28,4	4,00 101,6	8,63 219,2	9,69 246,1	10,62 269,7	8	0,88 22,4	11,75 298,5	38,8 17,6
10"	10,75 273	16,00 406,4	10,02 254,5	1,19 30,2	4,00 101,6	10,75 273,1	12,00 304,8	12,75 323,9	12	1,00 25,4	14,25 362,0	53,0 24,0
12"	12,75 323,8	19,00 482,6	12,00 304,8	1,25 31,8	4,50 114,3	12,75 323,9	14,38 365,3	15,00 381,0	12	1,00 25,4	17,00 431,8	80,4 36,5
14"	14,0 355,6	21,00 533,4	To be specified by purchaser	1,38 35,1	5,00 127,0	14,00 355,6	15,75 400,1	16,25 412,8	12	1,12 28,4	18,75 476,3	107 48,4
16"	16,0 406,4	23,50 596,9		1,44 36,6	5,00 127,0	16,00 406,4	18,00 457,2	18,50 469,9	16	1,12 28,4	21,25 539,8	134 60,6
18"	18,0 457,2	25,00 635,0		1,56 39,6	5,50 139,7	18,00 457,2	19,88 505,0	21,00 533,4	16	1,25 31,8	22,75 577,9	151 68,3
20"	20,0 508	27,50 698,5		1,69 42,9	5,69 144,5	20,00 508,0	22,00 558,8	23,00 584,2	20	1,25 31,8	25,00 635,0	186 84,5
24"	24,0 609,6	32,00 812,8		1,88 47,8	6,00 152,4	24,00 609,6	26,12 663,4	27,25 692,2	20	1,38 35,1	29,50 749,3	253 115

300 lb/sq. in. Welding Neck Flanges

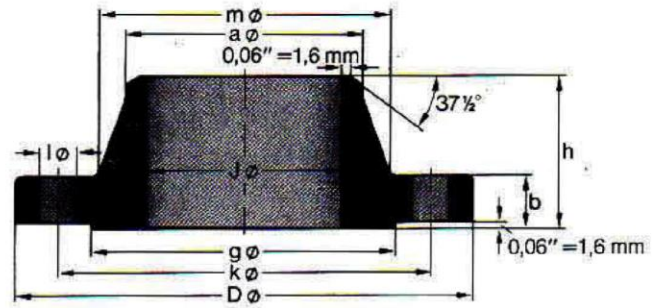

ANSI B 16.5

Pipe		Flange				Hub		Raised Face	Drilling Template			Approx. Weight
Nom. Size	OD in. mm	D in. mm	J in. mm	b in. mm	h in. mm	a in. mm	m in. mm	g in. mm	Number	l in. mm	k in. mm	≈ Pounds Kilo
1/2"	0.84 21.3	3.75 95.2	0.62 15.7	0.56 14.2	2.06 52.3	0.84 21.3	1.50 38.1	1.38 35.0	4	0.62 15.7	2.62 66.5	1.7 0.75
3/4"	1.05 26.7	4.62 117.3	0.82 20.8	0.62 15.7	2.25 57.1	1.05 26.7	1.88 47.7	1.69 42.9	4	0.75 19.0	3.25 82.5	2.8 1.26
1"	1.315 33.4	4.88 123.9	1.05 26.7	0.69 17.5	2.44 62.0	1.32 33.5	2.12 53.8	2.00 50.8	4	0.75 19.0	3.50 88.9	3.5 1.52
1 1/4"	1.66 42.2	5.25 133.3	1.38 35.1	0.75 19.0	2.56 65.0	1.66 42.2	2.50 63.5	2.50 63.5	4	0.75 19.0	3.88 98.5	4.5 2.03
1 1/2"	1.90 48.3	6.12 155.4	1.61 40.9	0.81 20.6	2.69 68.3	1.90 48.3	2.75 69.8	2.88 73.1	4	0.88 22.3	4.50 114.3	6.4 2.89
2"	2.375 60.3	6.50 165.1	2.07 52.6	0.88 22.3	2.75 69.8	2.38 60.4	3.31 84.0	3.62 91.9	8	0.75 19.0	5.00 127.0	7.5 3.40
2 1/2"	2.875 73.0	7.50 190.5	2.47 62.7	1.00 25.4	3.00 76.2	2.88 73.1	3.94 100.0	4.12 104.6	8	0.88 22.3	5.88 149.3	11.4 5.17
3"	3.50 88.9	8.25 209.5	3.07 78.0	1.12 28.4	3.12 79.2	3.50 88.9	4.62 117.3	5.00 127.0	8	0.88 22.3	6.62 168.1	15.3 6.93
3 1/2"	4.00 101.6	9.00 228.6	3.55 90.2	1.19 30.2	3.19 81.0	4.00 101.6	5.25 133.3	5.50 139.7	8	0.88 22.3	7.25 184.1	19.1 8.67
4"	4.50 114.3	10.00 254.0	4.03 102.4	1.25 31.7	3.38 85.8	4.50 114.3	5.75 146.0	6.19 157.2	8	0.88 22.3	7.88 200.1	24.7 11.2
5"	5.563 141.3	11.00 279.4	5.05 128.3	1.38 35.0	3.88 98.5	5.56 141.2	7.00 177.8	7.31 185.6	8	0.88 22.3	9.25 234.9	33.3 15.1
6"	6.625 168.3	12.50 317.5	6.07 154.2	1.44 36.5	3.88 98.5	6.63 168.4	8.12 206.2	8.50 215.9	12	0.88 22.3	10.62 269.7	42.4 19.1
8"	8.625 219.1	15.00 381.0	7.98 202.7	1.62 41.1	4.38 111.2	8.63 219.2	10.25 260.3	10.62 269.7	12	1.00 25.4	13.00 330.2	65.9 29.9
10"	10.75 273	17.50 444.5	10.02 254.5	1.88 47.7	4.62 117.3	10.75 273	12.62 320.5	12.75 323.8	16	1.12 28.4	15.25 387.3	94.1 42.7
12"	12.75 323.8	20.50 520.7	12.00 304.8	2.00 50.8	5.12 130.0	12.75 323.8	14.75 374.6	15.00 381.0	16	1.25 31.7	17.75 450.8	136 61.8
14"	14.00 355.6	23.00 584.2	To be specified by purchaser	2.12 53.8	5.62 142.7	14.00 355.6	16.75 425.4	16.25 412.7	20	1.25 31.7	20.25 514.3	189 85.8
16"	16.00 406.4	25.50 647.7		2.25 57.1	5.75 146.0	16.00 406.4	19.00 482.6	18.50 469.9	20	1.38 35.0	22.50 571.5	234 106
18"	18.00 457.2	28.00 711.2		2.38 60.4	6.25 158.7	18.00 457.2	21.00 533.4	21.00 533.4	24	1.38 35.0	24.75 628.6	289 131
20"	20.00 508	30.50 774.7		2.50 63.5	6.38 162.0	20.00 508	23.12 587.2	23.00 584.2	24	1.38 35.0	27.00 685.8	348 158
24"	24.00 609.6	36.00 914.4		2.75 69.8	6.62 168.1	24.00 609.6	27.62 701.5	27.25 692.1	24	1.62 41.1	32.00 812.8	507 230

**600 lb/sq. in.
Welding Neck Flanges**

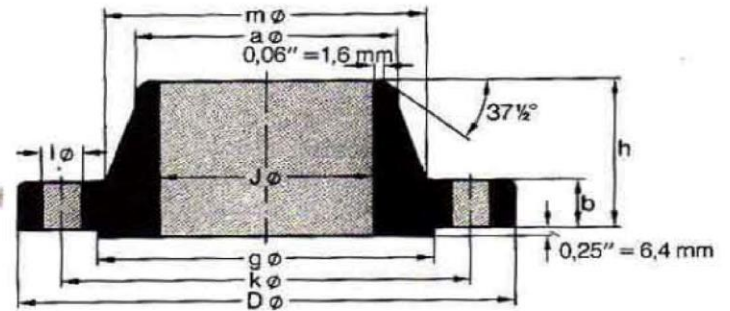

ANSI B 16.5

Pipe		Flange			Hub		Raised Face	Drilling Template			Approx. Weight	
Nom Size	O D in. mm	D in. mm	J in. mm	b in. mm	h in. mm	a in. mm	m in. mm	g in. mm	Number	l in. mm	k in. mm	≈ Pounds Kilo
1/2"	0.84	3.75	0.56	2.06	0.84	1.50	1.38	4	0.62	2.62	1.9	
	21.3	95.3		14.2	52.3	21.3	38.1	35.1	15.7	66.5	0.87	
3/4"	1.05	4.62	0.62	2.25	1.05	1.88	1.69	4	0.75	3.25	3.2	
	26.7	117.3		15.7	57.2	26.7	47.8	42.9	19.1	82.6	1.45	
1"	1.315	4.88	0.69	2.44	1.32	2.12	2.00	4	0.75	3.50	3.9	
	33.4	124.0		17.5	62.0	33.5	53.8	50.8	19.1	88.9	1.76	
1 1/4"	1.66	5.25	0.81	2.62	1.66	2.50	2.50	4	0.75	3.88	5.5	
	42.2	133.4		20.6	66.5	42.2	63.5	63.5	19.1	98.6	2.49	
1 1/2"	1.90	6.12	0.88	2.75	1.90	2.75	2.88	4	0.88	4.50	7.7	
	48.3	155.4		22.4	69.9	48.3	69.9	73.2	22.4	114.3	3.49	
2"	2.375	6.50	1.00	2.88	2.38	3.31	3.62	8	0.75	5.00	9.6	
	60.3	165.1		25.4	73.2	60.5	84.1	91.9	19.1	127.0	4.36	
2 1/2"	2.875	7.50	1.12	3.12	2.88	3.94	4.12	8	0.88	5.88	14.2	
	73.0	190.5		28.4	79.2	73.2	100.1	104.6	22.4	149.4	6.43	
3"	3.50	8.25	1.25	3.25	3.50	4.62	5.00	8	0.88	6.62	18.8	
	88.9	209.6		31.8	82.6	88.9	117.3	127.0	22.4	168.1	8.53	
3 1/2"	4.00	9.00	1.38	3.38	4.00	5.25	5.50	8	1.00	7.25	23.6	
	101.6	228.6		35.1	85.9	101.6	133.4	139.7	25.4	184.2	10.7	
4"	4.50	10.75	1.50	4.00	4.50	6.00	6.19	8	1.00	8.50	38.3	
	114.3	273.1		38.1	101.6	114.3	152.4	157.2	25.4	215.9	17.4	
5"	5.563	13.00	1.75	4.50	5.56	7.44	7.31	8	1.12	10.50	64.3	
	141.3	330.2		44.5	114.3	141.2	189.0	185.7	28.4	266.7	29.2	
6"	6.625	14.00	1.88	4.62	6.63	8.75	8.50	12	1.12	11.50	76.9	
	168.3	355.6		47.8	117.3	168.4	222.3	215.9	28.4	292.1	34.9	
8"	8.625	16.50	2.19	5.25	8.63	10.75	10.62	12	1.25	13.75	119	
	219.1	419.1		55.6	133.4	219.2	273.1	269.7	31.8	349.3	53.9	
10"	10.75	20.00	2.50	6.00	10.75	13.50	12.75	16	1.38	17.00	191	
	273	508.0		63.5	152.4	273.1	342.9	323.9	35.1	431.8	86.5	
12"	12.75	22.00	2.62	6.12	12.75	15.75	15.00	20	1.38	19.25	227	
	323.8	558.8		66.5	155.4	323.9	400.1	381.0	35.1	489.0	103	
14"	14.0	23.75	2.75	6.50	14.00	17.00	16.25	20	1.50	20.75	269	
	355.6	603.3		69.9	165.1	355.6	431.8	412.8	38.1	527.1	122	
16"	16.0	27.00	3.00	7.00	16.00	19.50	18.50	20	1.62	23.75	374	
	406.4	685.8		76.2	177.8	406.4	495.3	469.9	41.1	603.3	170	
18"	18.0	29.25	3.25	7.25	18.00	21.50	21.00	20	1.75	25.75	449	
	457.2	743.0		82.6	184.2	457.2	546.1	533.4	44.5	654.1	204	
20"	20.0	32.00	3.50	7.50	20.00	24.00	23.00	24	1.75	28.50	560	
	508	812.8		88.9	190.5	508.0	609.6	584.2	44.5	723.9	254	
24"	24.0	37.00	4.00	8.00	24.00	28.25	27.25	24	2.00	33.00	789	
	609.6	939.8		101.6	203.2	609.6	717.6	692.2	50.8	838.2	358	

To be specified by purchaser

Facing

Ring Joint Facings

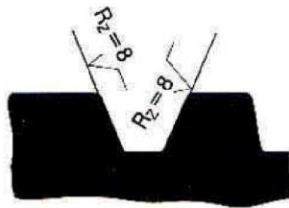

R_2 in μm

Tongue/Groove
Small Male/Female Facings

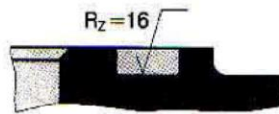

R_2 in μm

Stock Finish
Large Male/Female Facings

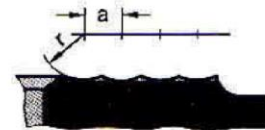

Nominal Size

	12" 300 mm	> 12" > 300 mm
r (mm)	1,2 - 1,6	1,6 - 3,2
a (mm/U)	0,75 - 0,9	0,8 - 1,0

Facings in other design on enquiry.

Welding Ends ANSI B 16.25

a = Outside diameter of pipe

J = Inside diameter of pipe

t = Wall thickness of pipe

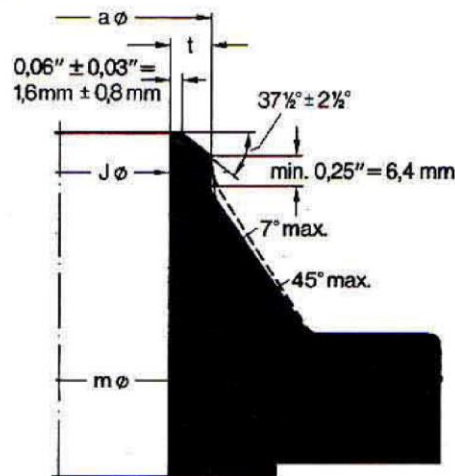

Bevel for Wall Thicknesses (t) 0,19" to 0,88" inclusive

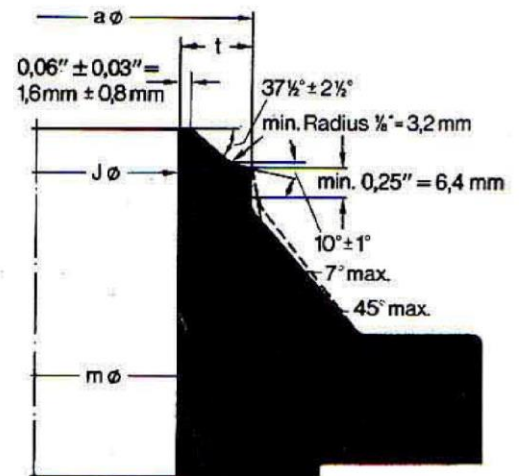

Bevel for Wall Thicknesses (t) greater than 0,88"

300 lb/sq. in. Slip-on Flanges

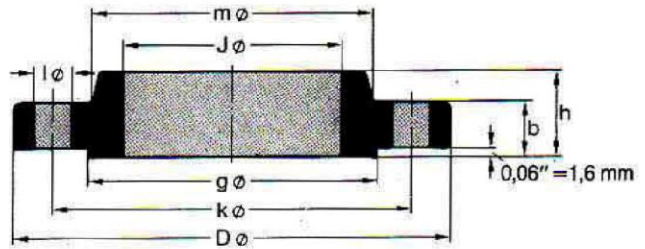

ANSI B 16.5

Pipe		Flange				Hub	Raised Face	Drilling Template			Approx. Weight
Nom. Size	OD in. mm	D in. mm	J in. mm	b in. mm	h in. mm	m in. mm	g in. mm	Number	l in. mm	k in. mm	≈ Pounds Kilo
1/2"	0,84 21,3	3,75 95,2	0,88 22,3	0,56 14,2	0,88 22,3	1,50 38,1	1,38 35,0	4	0,62 15,7	2,62 66,5	1,4 0,64
3/4"	1,05 26,7	4,62 117,3	1,09 27,7	0,62 15,7	1,00 25,4	1,88 47,7	1,69 42,9	4	0,75 19,0	3,25 82,5	2,5 1,12
1"	1,315 33,4	4,88 123,9	1,36 34,5	0,69 17,5	1,06 26,9	2,12 53,8	2,00 50,8	4	0,75 19,0	3,50 88,9	3,0 1,36
1 1/4"	1,66 42,2	5,25 133,3	1,70 43,2	0,75 19,0	1,06 26,9	2,50 63,5	2,50 63,5	4	0,75 19,0	3,88 98,5	3,7 1,68
1 1/2"	1,90 48,3	6,12 155,4	1,95 49,5	0,81 20,6	1,19 30,2	2,75 69,8	2,88 73,1	4	0,88 22,3	4,50 114,3	5,5 2,49
2"	2,375 60,3	6,50 165,1	2,44 62,0	0,88 22,3	1,31 33,2	3,31 84,0	3,62 91,9	8	0,75 19,0	5,00 127,0	6,3 2,87
2 1/2"	2,875 73,0	7,50 190,5	2,94 74,7	1,00 25,4	1,50 38,1	3,94 100,0	4,12 104,6	8	0,88 22,3	5,88 149,3	9,5 4,32
3"	3,50 88,9	8,25 209,5	3,57 90,7	1,12 28,4	1,69 42,9	4,62 117,3	5,00 127,0	8	0,88 22,3	6,62 168,1	12,9 5,85
3 1/2"	4,00 101,6	9,00 228,6	4,07 103,4	1,19 30,2	1,75 44,4	5,25 133,3	5,50 139,7	8	0,88 22,3	7,25 184,1	16,2 7,34
4"	4,50 114,3	10,00 254,0	4,57 116,1	1,25 31,7	1,88 47,7	5,75 146,0	6,19 157,2	8	0,88 22,3	7,88 200,1	21,2 9,61
5"	5,563 141,3	11,00 279,4	5,66 143,8	1,38 35,0	2,00 50,8	7,00 177,8	7,31 185,6	8	0,88 22,3	9,25 234,9	27,1 12,3
6"	6,625 168,3	12,50 317,5	6,72 170,7	1,44 36,5	2,06 52,3	8,12 206,2	8,50 215,9	12	0,88 22,3	10,62 269,7	34,4 15,6
8"	8,625 219,1	15,00 381,0	8,72 221,5	1,62 41,1	2,44 61,9	10,25 260,3	10,62 269,7	12	1,00 25,4	13,00 330,2	53,3 24,2
10"	10,75 273	17,50 444,5	10,88 276,3	1,88 47,7	2,62 66,5	12,62 320,5	12,75 323,8	16	1,12 28,4	15,25 387,3	75,1 34,1
12"	12,75 323,8	20,50 520,7	12,88 327,1	2,00 50,8	2,88 73,1	14,75 374,6	15,00 381,0	16	1,25 31,7	17,75 450,8	110 49,8
14"	14,0 355,6	23,00 584,2	14,14 359,1	2,12 53,8	3,00 76,2	16,75 425,4	16,25 412,7	20	1,25 31,7	20,25 514,3	154 69,9
16"	16,0 406,4	25,50 647,7	16,16 410,5	2,25 57,1	3,25 82,5	19,00 482,6	18,50 469,9	20	1,38 35,0	22,50 571,5	194 88,1
18"	18,0 457,2	28,00 711,2	18,18 461,8	2,38 60,4	3,50 88,9	21,00 533,4	21,00 533,4	24	1,38 35,0	24,75 628,6	240 109
20"	20,0 508	30,50 774,7	20,20 513,1	2,50 63,5	3,75 95,2	23,12 587,2	23,00 584,2	24	1,38 35,0	27,00 685,8	295 134
24"	24,0 609,6	36,00 914,4	24,25 615,9	2,75 69,8	4,19 106,4	27,62 701,5	27,25 692,1	24	1,38 41,1	32,00 812,8	443 201

**600 lb/sq. in.
Slip-on Flanges**

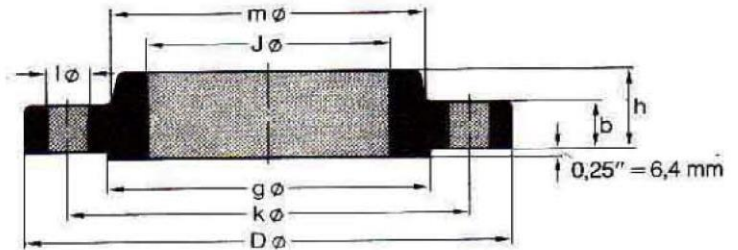

ANSI B 16.5

Pipe		Flange			Hub	Raised Face	Drilling Template			Approx. Weight	
Nom. Size	OD in. mm	D in. mm	J in. mm	b in. mm	h in. mm	m in. mm	g in. mm	Number	l in. mm	k in. mm	≈ Pounds Kilo
1/2"	0.84 21.3	3.75 95.3	0.88 22.4	0.56 14.2	0.88 22.4	1.50 38.1	1.38 35.1	4	0.62 15.7	2.62 66.5	1.6 0.74
3/4"	1.05 26.7	4.62 117.3	1.09 27.7	0.62 15.7	1.00 25.4	1.88 47.8	1.69 42.9	4	0.75 19.1	3.25 82.6	2.8 1.27
1"	1.315 33.4	4.88 124.0	1.36 34.5	0.69 17.5	1.06 26.9	2.12 53.8	2.00 50.8	4	0.75 19.1	3.50 88.9	3.3 1.52
1 1/4"	1.66 42.2	5.25 133.4	1.70 43.2	0.81 20.6	1.12 28.4	2.50 63.5	2.50 63.5	4	0.75 19.1	3.88 98.6	4.5 2.03
1 1/2"	1.90 48.3	6.12 155.4	1.95 49.5	0.88 22.4	1.25 31.8	2.75 69.9	2.88 73.2	4	0.88 22.4	4.50 114.3	6.5 2.96
2"	2.375 60.3	6.50 165.1	2.44 62.0	1.00 25.4	1.44 36.6	3.31 84.1	3.62 91.9	8	0.75 19.1	5.00 127.0	8.0 3.62
2 1/2"	2.875 73.0	7.50 190.5	2.94 74.7	1.12 28.4	1.62 41.1	3.94 100.1	4.12 104.6	8	0.88 22.4	5.88 149.4	11.6 5.28
3"	3.50 88.9	8.25 209.6	3.57 90.7	1.25 31.8	1.81 46.0	4.62 117.3	5.00 127.0	8	0.88 22.4	6.62 168.1	15.4 7.00
3 1/2"	4.00 101.6	9.00 228.6	4.07 103.4	1.38 35.1	1.94 49.3	5.25 133.4	5.50 139.7	8	1.00 25.4	7.25 184.2	19.5 8.84
4"	4.50 114.3	10.75 273.1	4.57 116.1	1.50 38.1	2.12 53.8	6.00 152.4	6.19 157.2	8	1.00 25.4	8.50 215.9	31.9 14.5
5"	5.563 141.3	13.00 330.2	5.66 143.8	1.75 44.5	2.38 60.5	7.44 189.0	7.31 185.7	8	1.12 28.4	10.50 266.7	53.7 24.4
6"	6.625 168.3	14.00 355.6	6.72 170.7	1.88 47.8	2.62 66.5	8.75 222.3	8.50 215.9	12	1.12 28.4	11.50 292.1	63.2 28.7
8"	8.625 219.1	16.50 419.1	8.72 221.5	2.19 55.6	3.00 76.2	10.75 273.1	10.62 269.7	12	1.25 31.8	13.75 349.3	95.6 43.4
10"	10.75 273	20.00 508.0	10.88 276.4	2.50 63.5	3.38 85.9	13.50 342.9	12.75 323.9	16	1.38 35.1	17.00 431.8	155 70.3
12"	12.75 323.8	22.00 558.8	12.88 327.2	2.62 66.5	3.62 91.9	15.75 400.1	15.00 381.0	20	1.38 35.1	19.25 489.0	186 84.2
14"	14.0 355.6	23.75 603.3	14.14 359.2	2.75 69.9	3.69 93.7	17.00 431.8	16.25 412.8	20	1.50 38.1	20.75 527.1	217 98.7
16"	16.0 406.4	27.00 685.8	16.16 410.5	3.00 76.2	4.19 106.4	19.50 495.3	18.50 469.9	20	1.62 41.1	23.75 603.3	313 142
18"	18.0 457.2	29.25 743.0	18.18 461.8	3.25 82.6	4.62 117.3	21.50 546.1	21.00 533.4	20	1.75 44.5	25.75 654.1	381 173
20"	20.0 508	32.00 812.8	20.20 513.1	3.50 88.9	5.00 127.0	24.00 609.6	23.00 584.2	24	1.75 44.5	28.50 723.9	485 220
24"	24.0 609.6	37.00 939.8	24.25 616.0	4.00 101.6	5.50 139.7	28.25 717.6	27.25 692.2	24	2.00 50.8	33.00 838.2	687 312

150 lb/sq. in. Blind Flanges

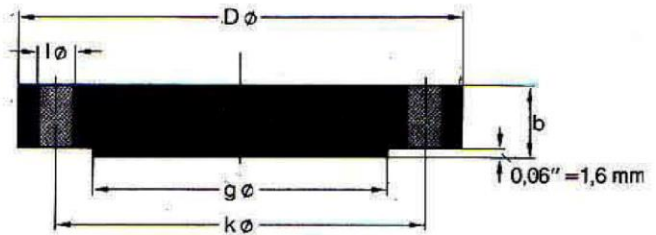

ANSI B 16.5

Pipe		Flange		Raised Face	Drilling Template			Approx. Weight
Nominal Size	O D in. mm	D in. mm	b in. mm	g in. mm	Number	l in. mm	k in. mm	≈ Pounds Kilo
1/2"	0,84 21,3	3,50 88,9	0,44 11,2	1,38 35,1	4	0,62 15,7	2,38 60,5	0,9 0,42
3/4"	1,05 26,7	3,88 98,6	0,50 12,7	1,69 42,9	4	0,62 15,7	2,75 69,9	1,3 0,61
1"	1,315 33,4	4,25 108,0	0,56 14,2	2,00 50,8	4	0,62 15,7	3,12 79,2	1,9 0,86
1 1/4"	1,66 42,2	4,62 117,3	0,62 15,7	2,50 63,5	4	0,62 15,7	3,50 88,9	2,6 1,17
1 1/2"	1,90 48,3	5,00 127,0	0,69 17,5	2,88 73,2	4	0,62 15,7	3,88 98,6	3,4 1,53
2"	2,375 60,3	6,00 152,4	0,75 19,1	3,62 91,9	4	0,75 19,1	4,75 120,7	5,3 2,42
2 1/2"	2,875 73,0	7,00 177,8	0,88 22,4	4,12 104,6	4	0,75 19,1	5,50 139,7	8,7 3,94
3"	3,50 88,9	7,50 190,5	0,94 23,9	5,00 127,0	4	0,75 19,1	6,00 152,4	10,9 4,93
3 1/2"	4,00 101,6	8,50 215,9	0,94 23,9	5,50 139,7	8	0,75 19,1	7,00 177,8	13,6 6,17
4"	4,50 114,3	9,00 228,6	0,94 23,9	6,19 157,2	8	0,75 19,1	7,50 190,5	15,4 7,00
5"	5,563 141,3	10,00 254,0	0,94 23,9	7,31 185,7	8	0,88 22,4	8,50 215,9	19,0 8,63
6"	6,625 168,3	11,00 279,4	1,00 25,4	8,50 215,9	8	0,88 22,4	9,50 241,3	24,9 11,3
8"	8,625 219,1	13,50 342,9	1,12 28,4	10,62 269,7	8	0,88 22,4	11,75 298,5	43,2 19,6
10"	10,75 273	16,00 406,4	1,19 30,2	12,75 323,9	12	1,00 25,4	14,25 362,0	63,4 28,8
12"	12,75 323,8	19,00 482,6	1,25 31,8	15,00 381,0	12	1,00 25,4	17,00 431,8	95,2 43,2
14"	14,0 355,6	21,00 533,4	1,38 35,1	16,25 412,8	12	1,12 28,4	18,75 476,3	128 58,1
16"	16,0 406,4	23,50 596,9	1,44 36,6	18,50 469,9	16	1,12 28,4	21,25 539,8	167 76,0
18"	18,0 457,2	25,00 635,0	1,56 39,6	21,00 533,4	16	1,25 31,8	22,75 577,9	206 93,7
20"	20,0 508	27,50 698,5	1,69 42,9	23,00 584,2	20	1,25 31,8	25,00 635,0	269 122
24"	24,0 609,6	32,00 812,8	1,88 47,8	27,25 692,2	20	1,38 35,1	29,50 749,3	408 185

300 lb/sq. in. Blind Flanges

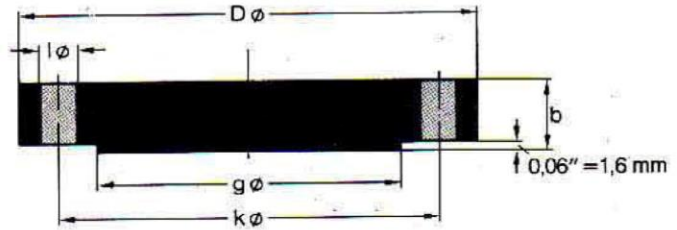

ANSI B 16.5

Pipe		Flange		Raised Face	Drilling Template			Approx. Weight
Nominal Size	OD in. mm	D in. mm	b in. mm	g in. mm	Number	l in. mm	k in. mm	≈ Pounds Kilo
1/2"	0,84 21,3	3,75 95,2	0,56 14,2	1,38 35,0	4	0,62 15,7	2,62 66,5	1,4 0,64
3/4"	1,05 26,7	4,62 117,3	0,62 15,7	1,69 42,9	4	0,75 19,0	3,25 82,5	2,4 1,11
1"	1,315 33,4	4,88 123,9	0,69 17,5	2,00 50,8	4	0,75 19,0	3,50 88,9	3,1 1,39
1 1/4"	1,66 42,2	5,25 133,3	0,75 19,0	2,50 63,5	4	0,75 19,0	3,88 98,5	3,9 1,79
1 1/2"	1,90 48,3	6,12 155,4	0,81 20,6	2,88 73,1	4	0,88 22,3	4,50 114,3	5,9 2,66
2"	2,375 60,3	6,50 165,1	0,88 22,3	3,62 91,9	8	0,75 19,0	5,00 127,0	7,0 3,18
2 1/2"	2,875 73,0	7,50 190,5	1,00 25,4	4,12 104,6	8	0,88 22,3	5,88 149,3	10,7 4,85
3"	3,50 88,9	8,25 209,5	1,12 28,4	5,00 127,0	8	0,88 22,3	6,62 168,1	15,0 6,81
3 1/2"	4,00 101,6	9,00 228,6	1,19 30,2	5,50 139,7	8	0,88 22,3	7,25 184,1	19,2 8,71
4"	4,50 114,3	10,00 254,0	1,25 31,7	6,19 157,2	8	0,88 22,3	7,88 200,1	25,3 11,5
5"	5,563 141,3	11,00 279,4	1,38 35,0	7,31 185,6	8	0,88 22,3	9,25 234,9	34,4 15,6
6"	6,625 168,3	12,50 317,5	1,44 36,5	8,50 215,9	12	0,88 22,3	10,62 269,7	46,0 20,9
8"	8,625 219,1	15,00 381,0	1,62 41,1	10,62 269,7	12	1,00 25,4	13,00 330,2	75,6 34,3
10"	10,75 273	17,50 444,5	1,88 47,7	12,75 323,8	16	1,12 28,4	15,25 387,3	117 53,3
12"	12,75 323,8	20,50 520,7	2,00 50,8	15,00 381,0	16	1,25 31,7	17,75 450,8	174 78,8
14"	14,0 355,6	23,00 584,2	2,12 53,8	16,25 412,7	20	1,25 31,7	20,25 514,3	231 105
16"	16,0 406,4	25,50 647,7	2,25 57,1	18,50 469,9	20	1,38 35,0	22,50 571,5	302 137
18"	18,0 457,2	28,00 711,2	2,38 60,4	21,00 533,4	24	1,38 35,0	24,75 628,6	386 175
20"	20,0 508	30,50 774,7	2,50 63,5	23,00 584,2	24	1,38 35,0	27,00 685,8	487 221
24"	24,0 609,6	36,00 914,4	2,75 69,8	27,25 692,1	24	1,62 41,1	32,00 812,8	747 339

600 lb/sq. in.
Blind Flanges

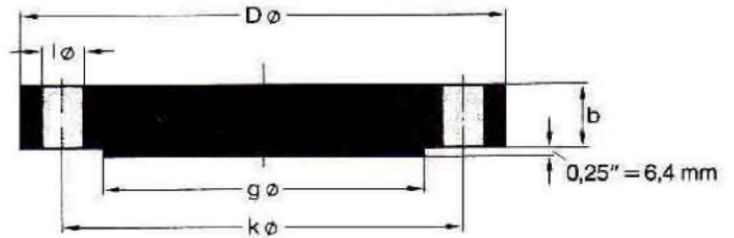

ANSI B 16.5

Nominal Size	Flange			Raised Face	Drilling Template			Approx. Weight ≈ Pounds Kilo
	O D in. mm	D in. mm	b in. mm		Number	l in. mm	k in. mm	
1/2"	0.84 21.3	3.75 95.3	0.56 14.2	1.38 35.1	4	0.62 15.7	2.62 66.5	1.7 0.76
3/4"	1.05 26.7	4.62 117.3	0.62 15.7	1.69 42.9	4	0.75 19.1	3.25 82.6	2.8 1.28
1"	1.315 33.4	4.88 124.0	0.69 17.5	2.00 50.8	4	0.75 19.1	3.50 88.9	3.5 1.60
1 1/4"	1.66 42.2	5.25 133.4	0.81 20.6	2.50 63.5	4	0.75 19.1	3.88 98.6	4.9 2.23
1 1/2"	1.90 48.3	6.12 155.4	0.88 22.4	2.88 73.2	4	0.88 22.4	4.50 114.3	7.2 3.25
2"	2.375 60.3	6.50 165.1	1.00 25.4	3.62 91.9	8	0.75 19.1	5.00 127.0	9.1 4.15
2 1/2"	2.875 73.0	7.50 190.5	1.12 28.4	4.12 104.6	8	0.88 22.4	5.88 149.4	13.5 6.13
3"	3.50 88.9	8.25 209.6	1.25 31.8	5.00 127.0	8	0.88 22.4	6.62 168.1	18.6 8.44
3 1/2"	4.00 101.6	9.00 228.6	1.38 35.1	5.50 139.7	8	1.00 25.4	7.25 184.2	24.2 11.0
4"	4.50 114.3	10.75 273.1	1.50 38.1	6.19 157.2	8	1.00 25.4	8.50 215.9	38.1 17.3
5"	5.563 141.3	13.00 330.2	1.75 44.5	7.31 185.7	8	1.12 28.4	10.50 266.7	64.8 29.4
6"	6.625 168.3	14.00 355.6	1.88 47.8	8.50 215.9	12	1.12 28.4	11.50 292.1	79.5 36.1
8"	8.625 219.1	16.50 419.1	2.19 55.6	10.62 269.7	12	1.25 31.8	13.75 349.3	130 58.9
10"	10.75 273	20.00 508.0	2.50 63.5	12.75 323.9	16	1.38 35.1	17.00 431.8	215 97.5
12"	12.75 323.8	22.00 558.8	2.62 66.5	15.00 381.0	20	1.38 35.1	19.25 489.0	273 124
14"	14.0 355.6	23.75 603.3	2.75 69.9	16.25 412.8	20	1.50 38.1	20.75 527.1	333 151
16"	16.0 406.4	27.00 685.8	3.00 76.2	18.50 469.9	20	1.62 41.1	23.75 603.3	471 214
18"	18.0 457.2	29.25 743.0	3.25 82.6	21.00 533.4	20	1.75 44.5	25.75 654.1	599 272
20"	20.0 508	32.00 812.8	3.50 88.9	23.00 584.2	24	1.75 44.5	28.50 723.9	769 349
24"	24.0 609.6	37.00 939.8	4.00 101.6	27.25 692.2	24	2.00 50.8	33.00 838.2	1174 533

Dimensional Tolerances

Welding Neck Flanges

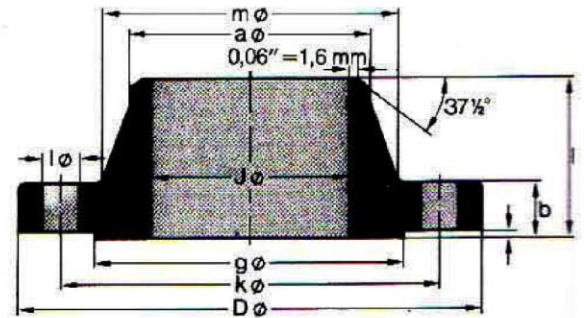

ANSI B 16.5

D	Outside Diameter ¹⁾	When OD is 24" or less When OD is over 24"	±0,06" ±1,6 mm ±0,12" ±3,2 mm
J	Inside Diameter	10" and smaller 12" to 18" 20" and larger	+0,03" +0,06" +0,12" - 0,06" +0,8 mm +1,6 mm +3,2 mm - 1,6 mm
g	Diameter of Contact Face	0,03" Raised Face 0,25" Raised Face Tongue and Groove, Male and Female	±0,03" ±0,8 mm ±0,02" ±0,5 mm ±0,02" ±0,5 mm
a	Diameter of Hub at Point of Welding	5" and smaller 6" and larger	+0,09" - 0,03" +0,16" - 0,03" +2,4 mm - 0,8 mm +4,0 mm - 0,8 mm
m	Diameter of Hub at Base ¹⁾	When Hub Base is 24" or less When Hub Base is over 24"	±0,06" ±1,6 mm ±0,12" ±3,2 mm
l	Drilling and Facing	Bolt Circle Diameter k Center-to-center of adjacent bolt holes Max. eccentricity between bolt circle dia. k and machined facing diameters: sizes 2½" and smaller sizes 3" and larger	±0,06" ±1,6 mm ±0,03" ±0,8 mm 0,03" 0,8 mm 0,06" 1,6 mm
h	Overall Length of Hub	10" and smaller 12" and larger	±0,06" ±1,6 mm ±0,12" ±3,2 mm
b	Thickness	18" and smaller 20" and larger	+0,12" +3,2 mm +0,19" +4,8 mm

1) This tolerance is not covered by ANSI B 16.5.



Dimensional Tolerances

Lap Joint, Slip-on, Threaded and Blind Flanges

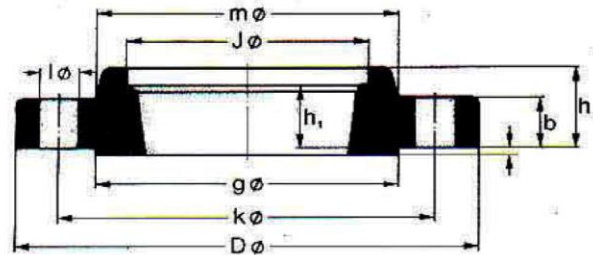

ANSI B 16.5

D	Outside Diameter ¹⁾	When OD is 24" or less When OD is over 24"	$\pm 0,06''$ $\pm 1,6$ mm $\pm 0,12''$ $\pm 3,2$ mm
J	Inside Diameter	Slip-on and Lap Joint 10" and smaller 12" and larger Threaded	+0,03" +0,8 mm +0,06" +1,6 mm Within limits on boring gauge
g	Diameter of Contact Face	Same as for Inside Diameter 0,03" Raised Face 0,25" Raised Face Tongue and Groove, Male and Female	$\pm 0,03''$ $\pm 0,8$ mm $\pm 0,02''$ $\pm 0,5$ mm $\pm 0,02''$ $\pm 0,5$ mm not for flanges with ring joint
m	Outside Diameter of Hub ¹⁾	12" and smaller 14" and larger	+0,09" - 0,06" $\pm 0,12''$ +2,4 mm - 1,6 mm $\pm 3,2$ mm
l	Drilling and Facing	Bolt Circle Diameter k Center-to-center of adjacent bolt holes Max. eccentricity between bolt circle dia. k and machined facing diameters: sizes 2 1/2" and smaller sizes 3" and larger	$\pm 0,06''$ $\pm 1,6$ mm $\pm 0,03''$ $\pm 0,8$ mm 0,03" 0,8 mm $\pm 0,06''$ 1,6 mm
h	Overall Length of Hub	18" and smaller 20" and larger	+0,12" - 0,03" +0,19" - 0,03" +3,2 mm - 0,8 mm +4,8 mm - 1,6 mm
b	Thickness	18" and smaller 20" and larger	+0,12" +3,2 mm, +0,19" +4,8 mm

1) This tolerance is not covered by ANSI B 16.5.

TF

300 lb/sq. in. Threaded Flanges

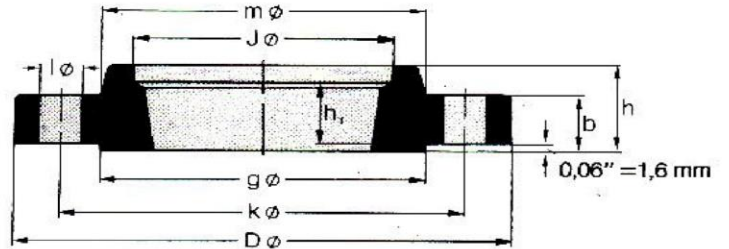

Thread type: Standard taper pipe thread to ANSI B 2.1

ANSI B 16.5

Pipe		Flange					Hub	Raised Face	Drilling Template			Approx. Weight
Nom. Size	OD in. mm	D in. mm	J in. mm	b in. mm	h in. mm	h in. mm	m in. mm	g in. mm	Number	l in. mm	k in. mm	~ Pounds Kilo
1/2"	0,84	3,75	0,93	0,56	0,88	0,62	1,50	1,38	4	0,62	2,62	1,4
	21,3	95,2	23,6	14,2	22,3	15,7	38,1	35,0		15,7	66,5	0,64
3/4"	1,05	4,62	1,14	0,62	1,00	0,62	1,88	1,69	4	0,75	3,25	2,5
	26,7	117,3	29,0	15,7	25,4	15,7	47,7	42,9		19,0	82,5	1,12
1"	1,315	4,88	1,41	0,69	1,06	0,69	2,12	2,00	4	0,75	3,50	3,0
	33,4	123,9	35,8	17,5	26,9	17,5	53,8	50,8		19,0	88,9	1,36
1 1/4"	1,66	5,25	1,75	0,75	1,06	0,81	2,50	2,50	4	0,75	3,88	3,7
	42,2	133,3	44,4	19,0	26,9	20,5	63,5	63,5		19,0	98,5	1,68
1 1/2"	1,90	6,12	1,99	0,81	1,19	0,88	2,75	2,88	4	0,88	4,50	5,5
	48,3	155,4	50,5	20,6	30,2	22,3	69,8	73,1		22,3	114,3	2,49
2"	2,375	6,50	2,50	0,88	1,31	1,12	3,31	3,62	8	0,75	5,00	6,3
	60,3	165,1	63,5	22,3	33,2	28,4	84,0	91,9		19,0	127,0	2,87
2 1/2"	2,875	7,50	3,00	1,00	1,50	1,25	3,94	4,12	8	0,88	5,88	9,5
	73,0	190,5	76,2	25,4	38,1	31,7	100,0	104,6		22,3	149,3	4,32
3"	3,50	8,25	3,63	1,12	1,69	1,25	4,62	5,00	8	0,88	6,62	12,9
	88,9	209,5	92,2	28,4	42,9	31,7	117,3	127,0		22,3	168,1	5,85
3 1/2"	4,00	9,00	4,13	1,19	1,75	1,44	5,25	5,50	8	0,88	7,25	16,2
	101,6	228,6	104,9	30,2	44,4	36,5	133,3	139,7		22,3	184,1	7,34
4"	4,50	10,00	4,63	1,25	1,88	1,44	5,75	6,19	8	0,88	7,88	21,2
	114,3	254,0	117,6	31,7	47,7	36,5	146,0	157,2		22,3	200,1	9,61
5"	5,563	11,00	5,69	1,38	2,00	1,69	7,00	7,31	8	0,88	9,25	27,1
	141,3	279,4	144,5	35,0	50,8	42,9	177,8	185,6		22,3	234,9	12,3
6"	6,625	12,50	6,75	1,44	2,06	1,81	8,12	8,50	12	0,88	10,62	34,4
	168,3	317,5	171,4	36,5	52,3	45,9	206,2	215,9		22,3	269,7	15,6
8"	8,625	15,00	8,75	1,62	2,44	2,00	10,25	10,62	12	1,00	13,00	53,3
	219,1	381,0	222,2	41,1	61,9	50,8	260,3	269,7		25,4	330,2	24,2
10"	10,75	17,50	10,88	1,88	2,62	2,19	12,62	12,75	16	1,12	15,25	75,1
	273	444,5	276,3	47,7	66,5	55,6	320,5	323,8		28,4	387,3	34,1
12"	12,75	20,50	12,94	2,00	2,88	2,38	14,75	15,00	16	1,25	17,75	110
	323,8	520,7	328,7	50,8	73,1	60,4	374,6	381,0		31,7	450,8	49,8
14"	14,0	23,00	14,19	2,12	3,00	2,50	16,75	16,25	20	1,25	20,25	154
	355,6	584,2	360,4	53,8	76,2	63,5	425,4	412,7		31,7	514,3	69,9
16"	16,0	25,50	16,19	2,25	3,25	2,69	19,00	18,50	20	1,38	22,50	194
	406,4	647,7	411,2	57,1	82,5	68,3	482,6	469,9		35,0	571,5	88,1
18"	18,0	28,00	18,19	2,38	3,50	2,75	21,00	21,00	24	1,38	24,75	240
	457,2	711,2	462	60,4	88,9	69,8	533,4	533,4		35,0	628,6	109
20"	20,0	30,50	20,19	2,50	3,75	2,88	23,12	23,00	24	1,38	27,00	295
	508	774,7	512,8	63,5	95,2	73,1	587,2	584,2		35,0	685,8	134
24"	24,0	36,00	24,19	2,75	4,19	3,25	27,62	27,25	24	1,62	32,00	443
	609,6	914,4	614,4	69,8	106,4	82,5	701,5	692,1		41,1	812,8	201

TF

150 lb/sq. in. Threaded Flanges

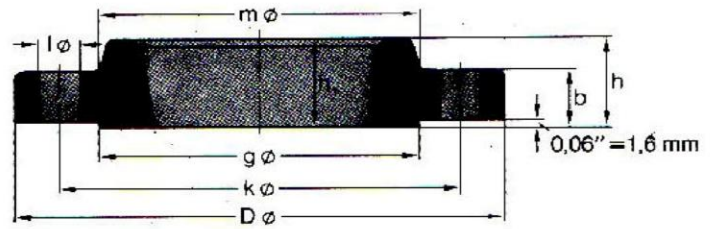

Thread type: Standard taper pipe thread to ANSI B 2.1

ANSI B 16.5

Pipe		Flange			Hub	Raised Face	Drilling Template			Approx. Weight	
Nom. Size	OD in. mm	D in. mm	J in. mm	b in. mm	h/h in. mm	m in. mm	g in. mm	Number	l in. mm	k in. mm	≈ Pounds Kilo
1/2"	0,84	3,50		0,44	0,62	1,19	1,38	4	0,62	2,38	0,9
	21,3	88,9		11,2	15,7	30,2	35,1		15,7	60,5	0,39
3/4"	1,05	3,88		0,50	0,62	1,50	1,69	4	0,62	2,75	1,2
	26,7	98,6		12,7	15,7	38,1	42,9		15,7	69,9	0,56
1"	1,315	4,25		0,56	0,69	1,94	2,00	4	0,62	3,12	1,7
	33,4	108,0		14,2	17,5	49,3	50,8		15,7	79,2	0,78
1 1/4"	1,66	4,62		0,62	0,81	2,31	2,50	4	0,62	3,50	2,3
	42,2	117,3		15,7	20,6	58,7	63,5		15,7	88,9	1,03
1 1/2"	1,90	5,00		0,69	0,88	2,56	2,88	4	0,62	3,88	2,9
	48,3	127,0		17,5	22,4	65,0	73,2		15,7	98,6	1,32
2"	2,375	6,00		0,75	1,00	3,06	3,62	4	0,75	4,75	4,5
	60,3	152,4		19,1	25,4	77,7	91,9		19,1	120,7	2,06
2 1/2"	2,875	7,00		0,88	1,12	3,56	4,12	4	0,75	5,50	7,2
	73,0	177,8		22,4	28,4	90,4	104,6		19,1	139,7	3,28
3"	3,50	7,50		0,94	1,19	4,25	5,00	4	0,75	6,00	8,5
	88,9	190,5		23,9	30,2	108,0	127,0		19,1	152,4	3,85
3 1/2"	4,00	8,50		0,94	1,25	4,81	5,50	8	0,75	7,00	10,6
	101,6	215,9		23,9	31,8	122,2	139,7		19,1	177,8	4,81
4"	4,50	9,00		0,94	1,31	5,31	6,19	8	0,75	7,50	11,7
	114,3	228,6		23,9	33,3	134,9	157,2		19,1	190,5	5,30
5"	5,563	10,00		0,94	1,44	6,44	7,31	8	0,88	8,50	13,4
	141,3	254,0		23,9	36,6	163,6	185,7		22,4	215,9	6,07
6"	6,625	11,00		1,00	1,56	7,56	8,50	8	0,88	9,50	16,4
	168,3	279,4		25,4	39,6	192,0	215,9		22,4	241,3	7,45
8"	8,625	13,50		1,12	1,75	9,69	10,62	8	0,88	11,75	26,7
	219,1	342,9		28,4	44,5	246,1	269,7		22,4	298,5	12,1
10"	10,75	16,00		1,19	1,94	12,00	12,75	12	1,00	14,25	36,3
	273	406,4		30,2	49,3	304,8	323,9		25,4	362,0	16,5
12"	12,75	19,00		1,25	2,19	14,38	15,00	12	1,00	17,00	57,7
	323,8	482,6		31,8	55,6	365,3	381,0		25,4	431,8	26,2
14"	14,0	21,00		1,38	2,25	15,75	16,25	12	1,12	18,75	76,2
	355,6	533,4		35,1	57,2	400,1	412,8		28,4	476,3	34,6
16"	16,0	23,50		1,44	2,50	18,00	18,50	16	1,12	21,25	98,7
	406,4	596,9		36,6	63,5	457,2	469,9		28,4	539,8	44,8
18"	18,0	25,00		1,56	2,69	19,88	21,00	16	1,25	22,75	108
	457,2	635,0		39,6	68,3	505,0	533,4		31,8	577,9	48,9
20"	20,0	27,50		1,69	2,88	22,00	23,00	20	1,25	25,00	136
	508	698,5		42,9	73,2	558,8	584,2		31,8	635,0	61,9
24"	24,0	32,00		1,88	3,25	26,12	27,25	20	1,38	29,50	191
	609,6	812,8		47,8	82,6	663,4	692,2		35,1	749,3	86,9

No Counter Bore Required on 150 lb Threaded Flanges

TF

600 lb/sq. in. Socket Welding Flanges

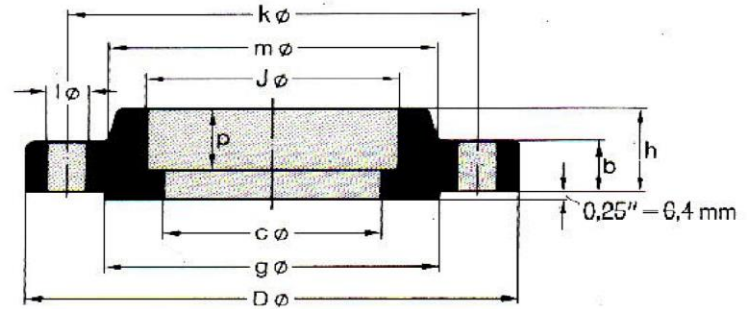

ANSI B 16.5

Pipe		Flange						Hub	Raised Face	Drilling Template			Approx. Weight
Nom. Size	O D in. mm	D in. mm	J in. mm	c in. mm	p in. mm	b in. mm	h in. mm	m in. mm	g in. mm	Number	l in. mm	k in. mm	≈ Pounds Kilo
1/2"	0,84 21,3	3,75 95,3	0,88 22,4	To be specified by purchaser	0,38	0,56 14,2	0,88 22,4	1,50 38,1	1,38 35,1	4	0,62 15,7	2,62 66,5	1,7 0,76
3/4"	1,05 26,7	4,62 117,3	1,09 27,7		0,44	0,62 15,7	1,00 25,4	1,88 47,8	1,69 42,9	4	0,75 19,1	3,25 82,6	2,6 1,29
1"	1,315 33,4	4,88 124,0	1,36 34,5		0,50	0,69 17,5	1,06 26,9	2,12 53,8	2,00 50,8	4	0,75 19,1	3,50 88,9	3,4 1,55
1 1/4"	1,66 42,2	5,25 133,4	1,70 43,2		0,56	0,81 20,6	1,12 28,4	2,50 63,5	2,50 63,5	4	0,75 19,1	3,88 98,6	4,5 2,06
1 1/2"	1,90 48,3	6,12 155,4	1,95 49,5		0,62	0,88 22,4	1,25 31,8	2,75 69,9	2,88 73,2	4	0,88 22,4	4,50 114,3	6,6 3,00
2"	2,375 60,3	6,50 165,1	2,44 62,0		0,69	1,00 25,4	1,44 36,6	3,31 84,1	3,62 91,9	8	0,75 19,1	5,00 127,0	8,1 3,67
2 1/2"	2,875 73,0	7,50 190,5	2,94 74,7		0,75	1,12 28,4	1,62 41,1	3,94 100,1	4,12 104,6	8	0,88 22,4	5,88 149,4	11,8 5,35
3"	3,50 88,9	8,25 209,6	3,57 90,7		0,81	1,25 31,8	1,81 46,0	4,62 117,3	5,00 127,0	8	0,88 22,4	6,62 168,1	15,6 7,06

1500 lb/sq. in. Socket Welding Flanges

ANSI B 16.5

Pipe		Flange						Hub	Raised Face	Drilling Template			Approx. Weight
Nom. Size	O D in. mm	D in. mm	J in. mm	c in. mm	p in. mm	b in. mm	h in. mm	m in. mm	g in. mm	Number	l in. mm	k in. mm	≈ Pounds Kilo
1/2"	0,84 21,3	4,75 120,6	0,88 22,3	To be specified by purchaser	0,38 9,6	0,88 22,3	1,25 31,7	1,50 38,1	1,38 35,0	4	0,88 22,3	3,25 82,5	4,0 1,80
3/4"	1,05 26,7	5,12 130,0	1,09 27,7		0,44 11,1	1,00 25,4	1,38 35,0	1,75 44,4	1,69 42,9	4	0,88 22,3	3,50 88,9	5,3 2,41
1"	1,315 33,4	5,88 149,3	1,36 34,5		0,50 12,7	1,12 28,4	1,62 41,1	2,06 52,3	2,00 50,8	4	1,00 25,4	4,00 101,6	7,8 3,55
1 1/4"	1,66 42,2	6,25 158,7	1,70 43,2		0,56 14,2	1,12 28,4	1,62 41,1	2,50 63,5	2,50 63,5	4	1,00 25,4	4,38 111,2	8,9 4,02
1 1/2"	1,90 48,3	7,00 177,8	1,95 49,5		0,62 15,7	1,25 31,7	1,75 44,5	2,75 69,8	2,88 73,1	4	1,12 28,4	4,88 123,9	12,0 5,45
2"	2,375 60,3	8,50 215,9	2,44 62,0		0,69 17,5	1,50 38,1	2,25 57,1	4,12 104,6	3,62 91,9	8	1,00 25,4	6,50 165,1	22,5 10,2
2 1/2"	2,875 73,0	9,62 244,3	2,94 74,7		0,75 19,0	1,62 41,1	2,50 63,5	4,88 123,9	4,12 104,6	8	1,12 28,4	7,50 190,5	30,6 13,9

TF

150 lb/sq. in. Socket Welding Flanges

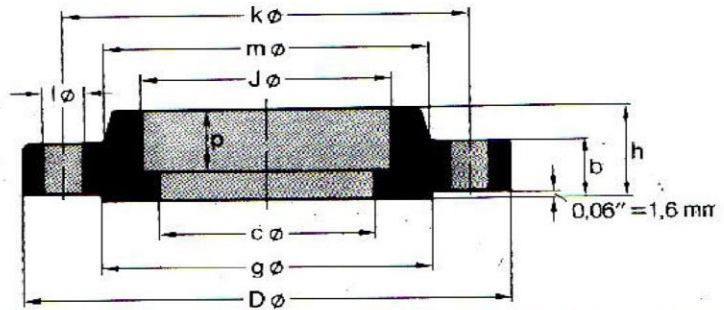

ANSI B 16.5

Pipe		Flange						Hub	Raised Face	Drilling Template			Approx. Weight
Nom. Size	OD in. mm	D in. mm	J in. mm	c in. mm	p in. mm	b in. mm	h in. mm	m in. mm	g in. mm	Number	l in. mm	k in. mm	≈ Pounds Kilo
1/2"	0.84 21.3	3.50 88.9	0.88 22.4	0.62 15.7	0.38 9.7	0.44 11.2	0.62 15.7	1.19 30.2	1.38 35.1	4	0.62 15.7	2.98 60.5	0.9 0.42
3/4"	1.05 26.7	3.88 98.6	1.09 27.7	0.82 20.8	0.44 11.2	0.50 12.7	0.62 15.7	1.50 38.1	1.69 42.9	4	0.62 15.7	2.75 69.9	1.3 0.59
1"	1.315 33.4	4.25 108.0	1.36 34.5	1.05 26.7	0.50 12.7	0.56 14.2	0.69 17.5	1.94 49.3	2.00 50.8	4	0.62 15.7	3.12 79.2	1.8 0.81
1 1/4"	1.66 42.2	4.62 117.3	1.70 43.2	1.38 35.1	0.56 14.2	0.62 15.7	0.81 20.6	2.31 58.7	2.50 63.5	4	0.62 15.7	3.50 88.9	2.4 1.07
1 1/2"	1.90 48.3	5.00 127.0	1.95 49.5	1.61 40.9	0.62 15.7	0.69 17.5	0.88 22.4	2.56 65.0	2.88 73.2	4	0.62 15.7	3.68 98.6	3.0 1.36
2"	2.375 60.3	6.00 152.4	2.44 62.0	2.07 52.6	0.69 17.5	0.75 19.1	1.00 25.4	3.06 77.7	3.62 91.9	4	0.75 19.1	4.75 120.7	4.6 2.10
2 1/2"	2.875 73.0	7.00 177.8	2.94 74.7	2.47 62.7	0.75 19.1	0.88 22.4	1.12 28.4	3.56 90.4	4.12 104.6	4	0.75 19.1	5.50 139.7	7.3 3.33
3"	3.50 88.9	7.50 190.5	3.57 90.7	3.07 78.0	0.81 20.6	0.94 23.9	1.19 30.2	4.25 108.0	5.00 127.0	4	0.75 19.1	6.00 152.4	8.6 3.90

300 lb/sq. in. Socket Welding Flanges ANSI B 16.5

Pipe		Flange						Hub	Raised Face	Drilling Template			Approx. Weight
Nom. Size	OD in. mm	D in. mm	J in. mm	c in. mm	p in. mm	b in. mm	h in. mm	m in. mm	g in. mm	Number	l in. mm	k in. mm	≈ Pounds Kilo
1/2"	0.84 21.3	3.75 95.2	0.88 22.3	0.62 15.7	0.38 9.6	0.56 14.2	0.88 22.3	1.50 38.1	1.38 35.0	4	0.62 15.7	2.62 66.5	1.5 0.66
3/4"	1.05 26.7	4.62 117.3	1.09 27.7	0.82 20.8	0.44 11.1	0.62 15.7	1.00 25.4	1.88 47.7	1.69 42.9	4	0.75 19.0	3.25 82.5	2.5 1.15
1"	1.315 33.4	4.88 123.9	1.36 34.5	1.05 26.7	0.50 12.7	0.69 17.5	1.06 26.9	2.12 53.8	2.00 50.8	4	0.75 19.0	3.50 88.9	3.1 1.40
1 1/4"	1.66 42.2	5.25 133.3	1.70 43.2	1.38 35.0	0.56 14.2	0.75 19.0	1.06 26.9	2.50 63.5	2.50 63.5	4	0.75 19.0	3.88 98.5	3.9 1.75
1 1/2"	1.90 48.3	6.12 155.4	1.95 49.5	1.61 40.9	0.62 15.7	0.81 20.6	1.19 30.2	2.75 69.8	2.88 73.1	4	0.88 22.3	4.50 114.3	5.6 2.55
2"	2.375 60.3	6.50 165.1	2.44 62.0	2.07 52.6	0.69 17.5	0.88 22.3	1.31 33.2	3.31 84.0	3.62 91.9	8	0.75 19.0	5.00 127.0	6.5 2.93
2 1/2"	2.875 73.0	7.50 190.5	2.94 74.7	2.47 62.7	0.75 19.0	1.00 25.4	1.50 38.1	3.94 100.0	4.12 104.6	8	0.88 22.3	5.88 149.3	9.7 4.40
3"	3.50 88.9	8.25 209.5	3.57 90.7	3.07 78.0	0.81 20.5	1.12 28.4	1.69 42.9	4.62 117.3	5.00 127.0	8	0.88 22.3	6.62 168.1	13.0 5.92